

1 TYPICAL 60'X120' LOT CONFIGURATION
SCALE: 1"=30'
*LOTS 2, 8, 18, AND 28 DO NOT MEET MINIMUM SETBACK SHOWN ABOVE

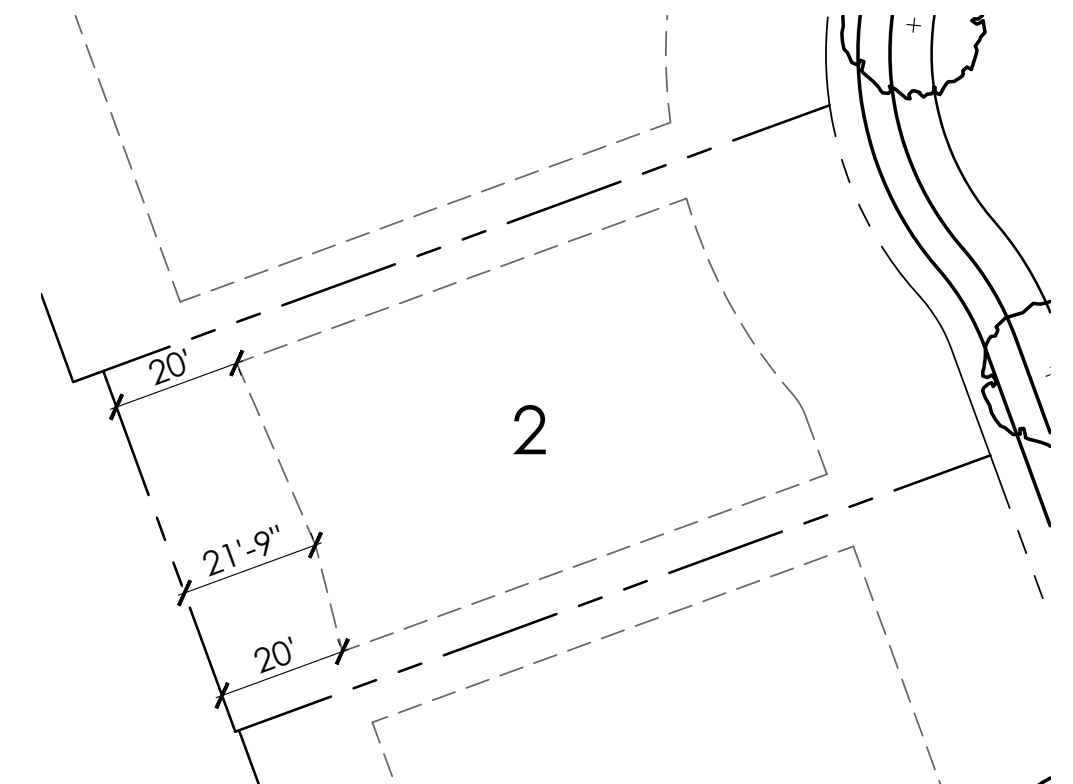

2 LOT 2 ENLARGEMENT
SCALE: 1"=30'

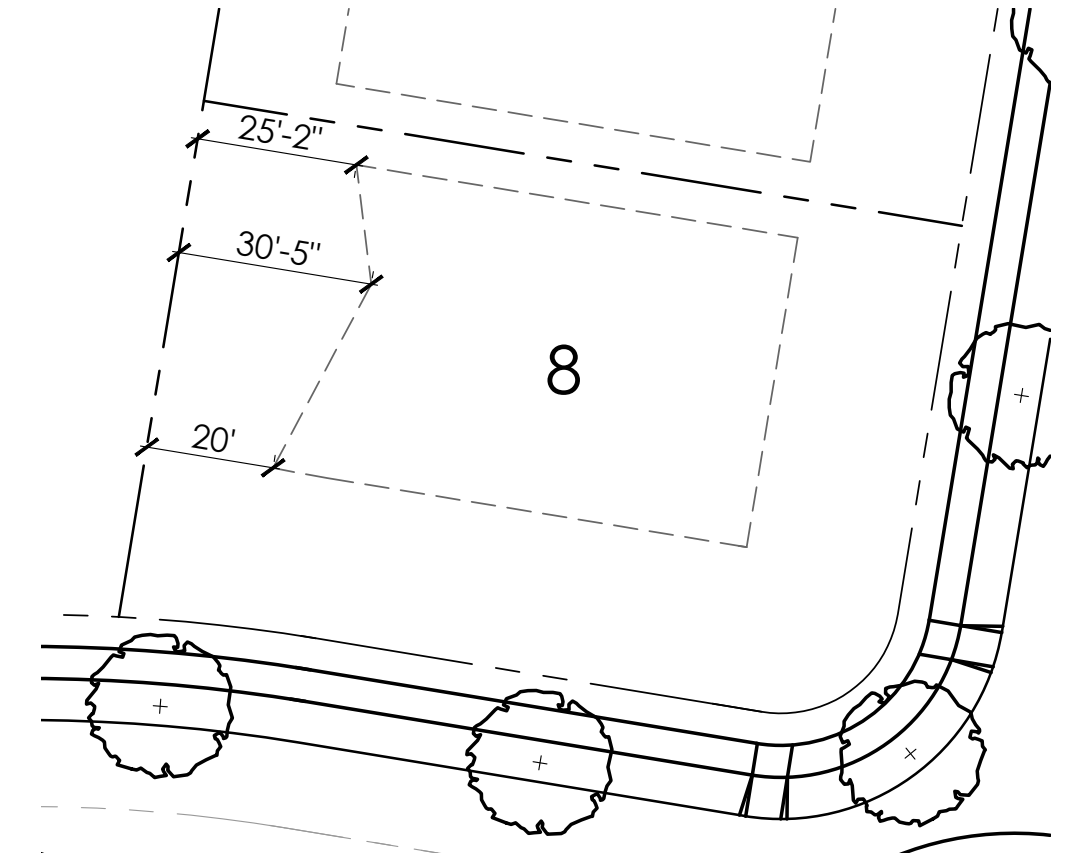

3 LOT 8 ENLARGEMENT
SCALE: 1"=30'

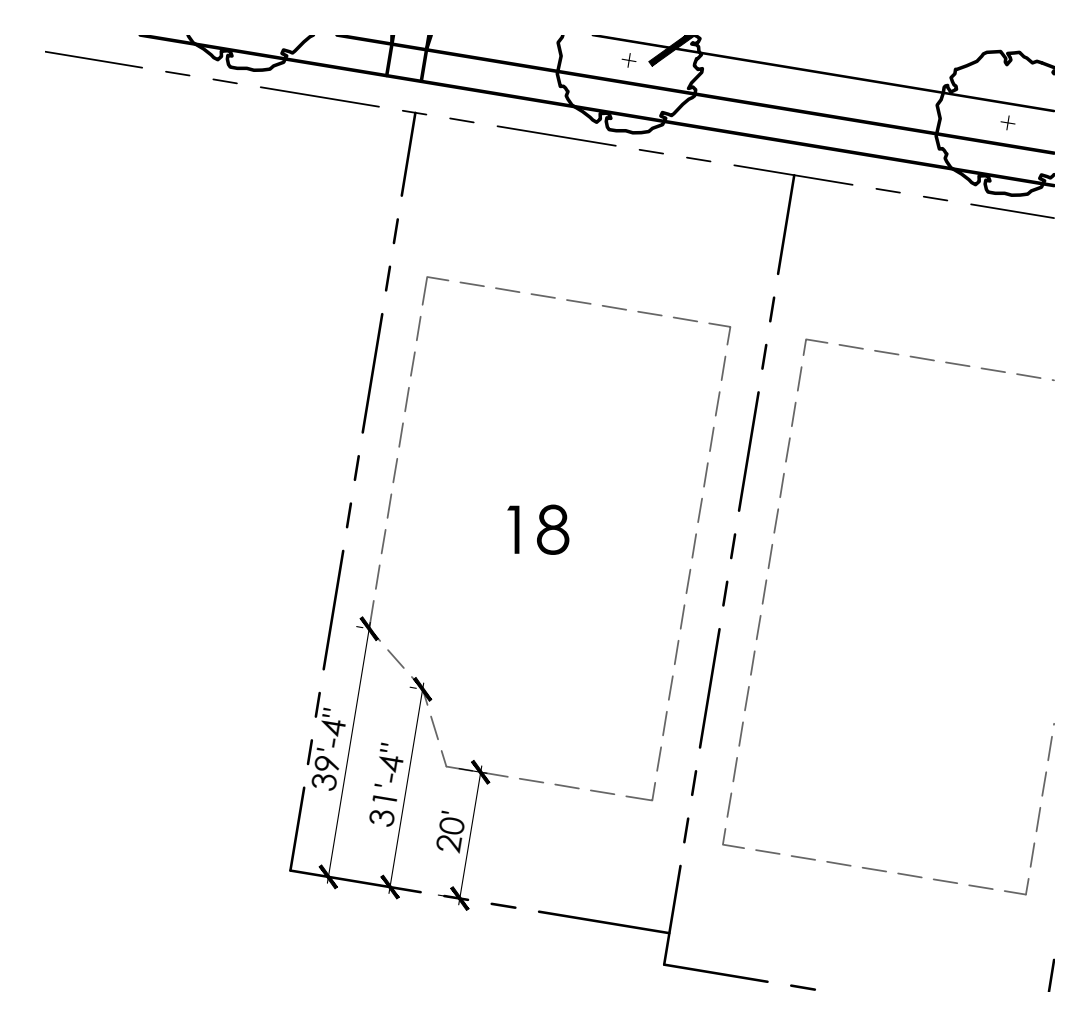

4 LOT 18 ENLARGEMENT
SCALE: 1"=30'

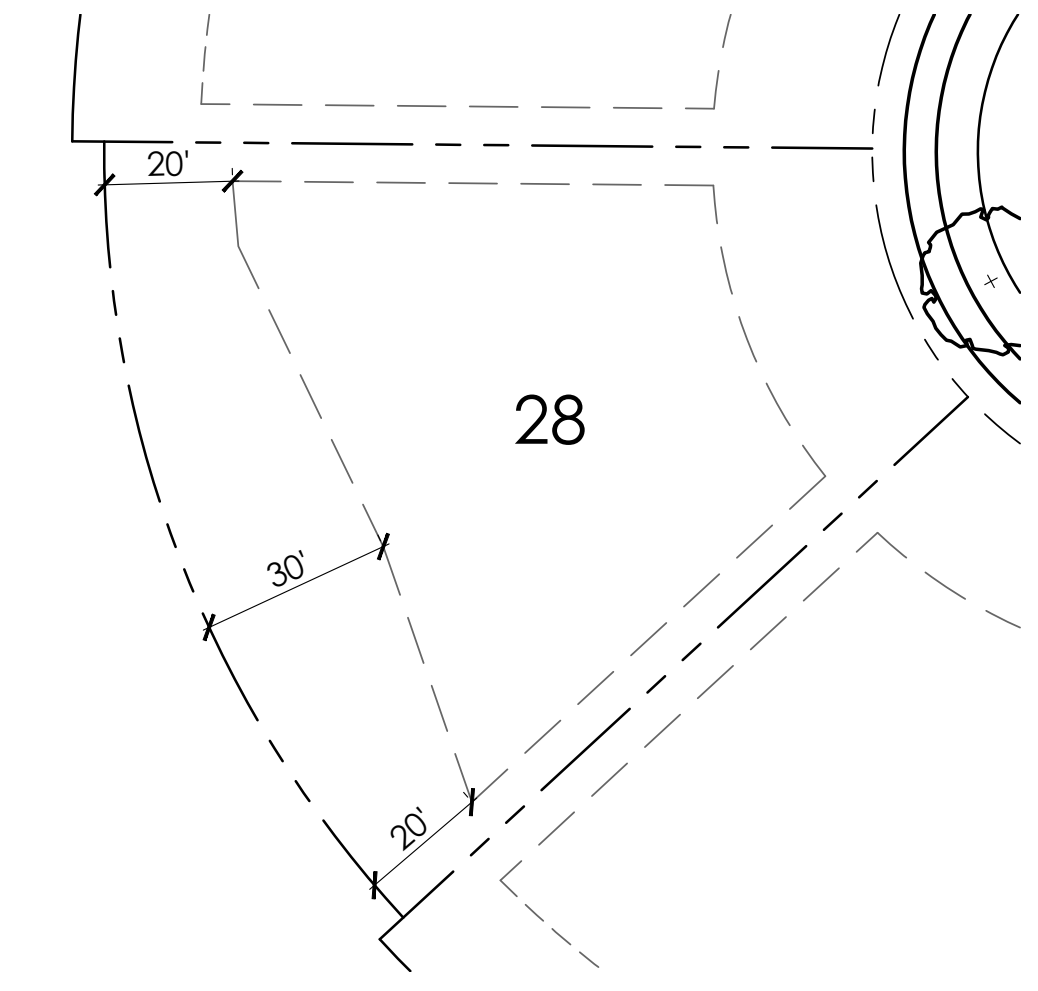

5 LOT 28 ENLARGEMENT
SCALE: 1"=30'

SITE DATA

TOTAL ACRES	±42.791 ACRES
TOTAL NET DEVELOPABLE ACRES	±33.8 ACRES
TOTAL UNITS	64
NET DU/AC	±1.89 DU/AC
GROSS DU/AC	±1.5 DU/AC
OPEN SPACE REQUIRED AT 50%	±21.40 AC
OPEN SPACE PROVIDED (±22.13 ACRES)	51.73%

PRELIMINARY DEVELOPMENT PLAN

EXHIBIT C-1

THE RAVINES AT HOOVER

PREPARED FOR BENALCAZAR
DATE: 3/23/18

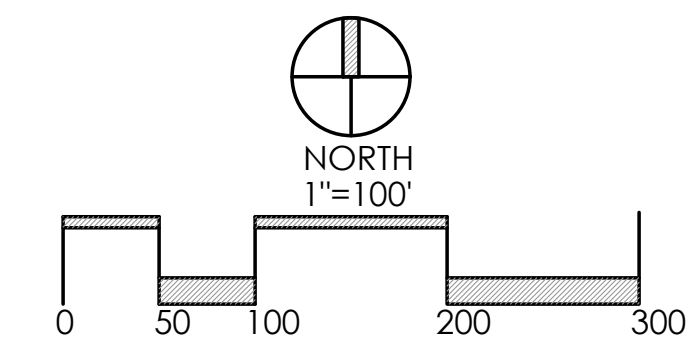

Faris Planning & Design

LAND PLANNING g LANDSCAPE ARCHITECTURE
243 N. 5th Street Suite 401 Columbus, OH 43215
p (614) 487-1964 www.farisplanninganddesign.com